

Mist Separator

AFM20/30/40

How to Order

AFM 30-F 03 BD-2R

Mist separator: AFM 30

Body size: 20 30 40

Thread type: Nil Rc, N NPT, F G

Accessories: B Nil, C Float type auto drain (N.C.), D Float type auto drain (N.O.)

Optional specifications: 2 Metal bowl, 6 Nylon bowl, 8 Metal bowl with level gauge, C With bowl guard, J Drain guide 1/4, R Flow direction: Right to left, W Drain cock with barb fitting, Z Name plate and caution plate

Note 1) Drain guide is NPT1/4 (applicable to AFM30 and 40), and the exhaust port for auto drain comes with ø3/8" One-touch fitting (applicable to AFM30 and 40).
 Note 2) Drain guide is G1/4 (applicable to AFM30 and 40).
 Note 3) Bracket is not assembled and is supplied loose at the time of shipment.
 Note 4) Applicable tube O.D for auto drain connection should be ø3/8" in case NPT thread port is chosen.
 Note 5) Without a valve function.
 Note 6) For NPT thread type.

* When more than one specification is required, indicate in ascending alphanumeric order.

This product is for overseas use only according to the new Measurement Law. (The SI unit type is provided for use in Japan.)

Accessory/Optional specification combinations

Combination	Symbol	Accessory			Optional specification							Applicable mist separator		
		B	C	D	2	6	8	C	J	R	W	Z	AFM20	AFM30 to 40
With bracket	B	○	○	○	○	○	○	○	○	○	○	△	○	○
Float type auto drain (N.C.)	C	○	○	○	○	○	○	○	○	○	○	△	○	○
Float type auto drain (N.O.)	D	○	○	○	○	○	○	○	○	○	○	△	○	○
Metal bowl	-2	○	○	○	○	○	○	○	○	○	○	△	○	○
Nylon bowl	-6	○	○	○	○	○	○	○	○	○	○	△	○	○
Metal bowl with level gauge	-8	○	○	○	○	○	○	○	○	○	○	△	○	○
With bowl guard	-C	○	○	○	○	○	○	○	○	○	○	△	○	○
Drain guide 1/4	-J	○	○	○	○	○	○	○	○	○	○	△	○	○
Flow direction: Right to left	-R	○	○	○	○	○	○	○	○	○	○	△	○	○
Drain cock with barb fitting: ø6 x ø4 nylon tubing	-W	○	○	○	○	○	○	○	○	○	○	△	○	○
Name plate and caution plate for bowl in imperial units (PSI, °F)	-Z	△	△	△	△	△	△	△	△	△	△	△	△	△

Standard Specifications

Model	AFM20	AFM30	AFM40	AFM40-06
Port sizes	1/8 1/4	1/4 3/8	1/4 3/8 1/2	3/4
Fluid	Air			
Proof pressure	1.5MPa			
Maximum operating pressure	1.0MPa			
Minimum operating pressure	0.05MPa			
Ambient and fluid temperature	-5 to 60°C (with no freezing)			
Rated flow L/min (ANR) Note 1)	200	450	1100	1100
Nominal filtration rating	0.3µm (95% filtered particle size)			
Outlet side oil mist concentration	Maximum 1.0mg/m ³ (ANR) (approx. 0.8ppm) Note 2)			
Bowl material	Polycarbonate			
Bowl guard	option	Standard		
Drain capacity (cm³)	8	25	45	45
Weight (kg)	0.18	0.22	0.44	0.49

Note 1) When the inlet pressure is 0.7MPa. Flow rate varies depending on the inlet pressure.
 Note 2) When the compressor oil mist discharge concentration is 30mgf/m³ (ANR).

Accessory part no.

Applicable model	AFM20	AFM30	AFM40	AFM40-06
Bracket assembly Note 1)	AF20P-050AS	AF30P-050AS	AF40P-050AS	AF40P-070AS
Float type auto drain Note 2)	N.O.	—	AD38 AD38N ^{Note 3)}	AD48 AD48N ^{Note 3)}
	N.C.	AD27	AD37 AD37N ^{Note 3)}	AD47 AD47N ^{Note 3)}

Note 1) Assembly includes a bracket and 2 mounting screws.
 Note 2) Minimum operating pressure: N.O. type-0.1MPa; N.C. type-0.1MPa (AD17/27) and 0.15MPa (AD37/47).
 Note 3) When "N" is specified in the end of part number of auto drain, applicable tube O.D should be ø3/8".



JIS symbol

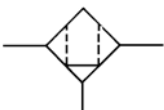

Flow Characteristics (Representative values)

— : When saturated with oil
 - - - : Initial state

AFM20

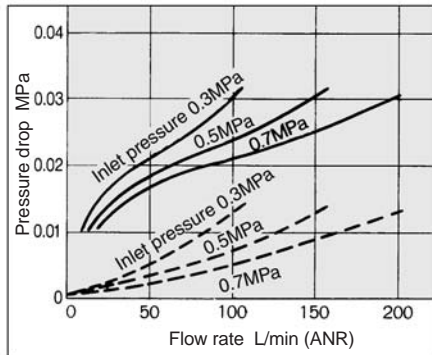

AFM30

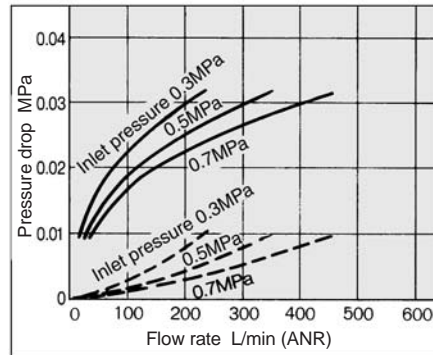

AFM40

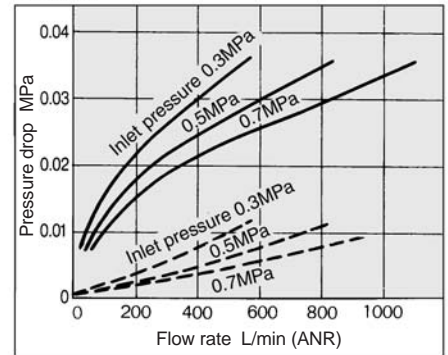

Construction

AFM20

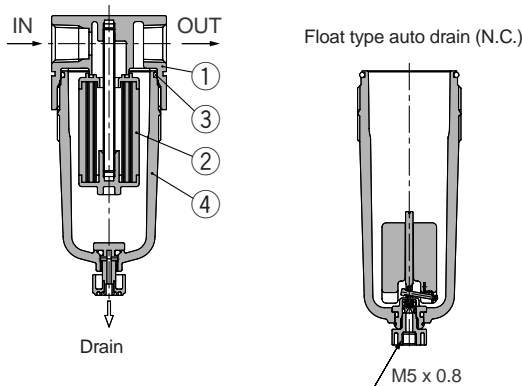

AFM30, 40

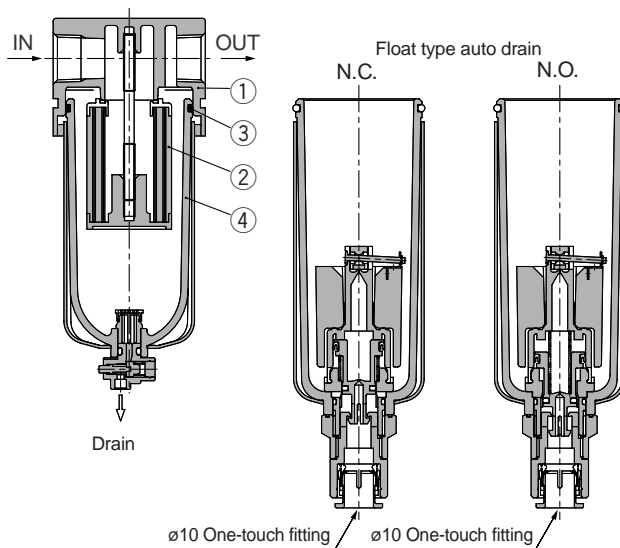

⚠ Specific Product Precautions

Be sure to read before handling. Refer to pages 75 through 78 for safety instructions and F.R.L. unit precautions.

Air Supply

⚠ Caution

1. Install an air filter (Series AF) as a preliminary filter on the inlet side of the mist separator to prevent premature clogging.
2. Do not install on the inlet side of the dryer as this can cause premature clogging of the element.

Maintenance

⚠ Warning

1. Replace the element every 2 years or when the pressure drop becomes 0.1MPa, whichever comes first, to prevent damage to the element.

Design

⚠ Caution

1. Design the system so that the mist separator is installed in a pulsation-free location. The difference between internal and external pressure inside the element should be kept within 0.1MPa, as exceeding this value could cause damage.

Selection

⚠ Caution

1. Do not allow air flow that exceeds the rated flow. If the air flow is allowed outside the range of the rated flow even momentarily, drainage and lubricant may splash at the outlet side or cause damage to the component.
2. Do not use in a low pressure application (such as a blower). F.R.L. unit has its own minimum operating pressure depending on the equipment and is designed specifically to function with compressed air. If used below the minimum operating pressure, a loss of performance and malfunction can occur. Contact SMC if an application under such conditions cannot be avoided.

Parts list

No.	Description	Material		Note
		AFM20	AFM30, AFM40, AFM40-06	
1	Body	Zinc die-cast	Aluminum die-cast	Platinum silver

Replacement parts

No.	Description	Material	Part no.			
			AFM20	AFM30	AFM40	AFM40-06
2	Element assembly	—	AFM20P-060AS	AFM30P-060AS	AFM40P-060AS	AFM40P-060AS
3	Bowl O-ring	NBR	C2SFP-260S	C3SFP-260S	C4SFP-260S	C4SFP-260S
4	Bowl assembly <small>Note 1)</small>	PC	C2SF	C3SF <small>Note 2)</small>	C4SF <small>Note 2)</small>	C4SF <small>Note 2)</small>

Note 1) Including O-Ring. Contact SMC regarding the bowl assembly supply for PSI and °F unit specifications.

Note 2) Bowl assembly for AFM30 to AFM40-06 includes a bowl guard (steel band material).

AFM20/30/40

Dimensions

AFM20

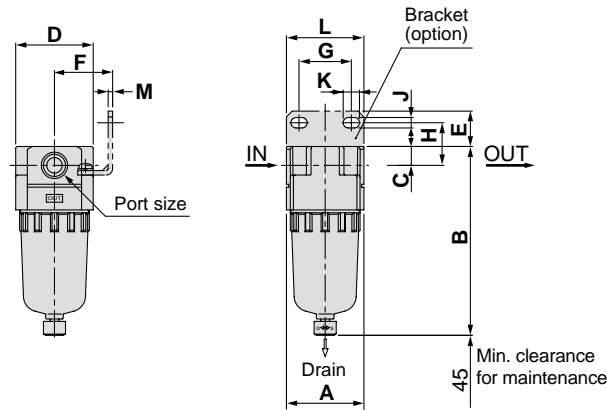

AFM30, 40, 40-06

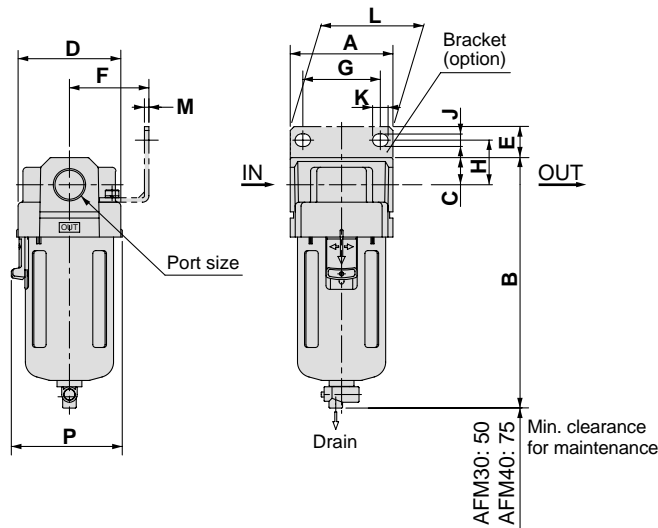

Applicable model	AFM20		AFM30, AFM40, AFM40-06				
	With auto drain (N.C.)	Metal bowl	With auto drain (N.O./N.C.)	Metal bowl	Metal bowl with level gauge	With drain guide	Drain cock with barb fitting
Optional specifications	M5 x 0.8		N.O.: Black N.C.: Grey ø10 One-touch fitting			1/4 Width across flats 17	Barb fitting Applicable tubing: T0604

Model	Port size	Standard specification					Accessory specification								
							With bracket								
		A	B	C	D	P	E	F	G	H	J	K	L	M	B
AFM20	1/8, 1/4	40	97	10	40	—	18	30	27	22	5.4	8.4	40	2.3	115
AFM30	1/4, 3/8	53	129	14	53	57	16	41	40	23	6.5	8	53	2.3	170
AFM40	1/4, 3/8, 1/2	70	165	18	70	73	17	50	54	26	8.5	10.5	70	2.3	204
AFM40-06	3/4	75	169	20	70	73	14	50	54	25	8.5	10.5	70	2.3	208

Model	Optional specification			
	With drain guide	With barb fitting	Metal bowl	Metal bowl with level gauge
	B	B	B	B
AFM20	—	—	97	—
AFM30	136	137	142	162
AFM40	172	173	178	198
AFM40-06	176	177	182	202